

REQUIRED CONTAMINATION CLASS	ISO 4406 class 20/18/15
OPERATING TEMPERATURE RANGE	-20° to +90°C

INLET	DIRECTION
A	RIGHT
B	LEFT

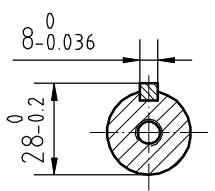
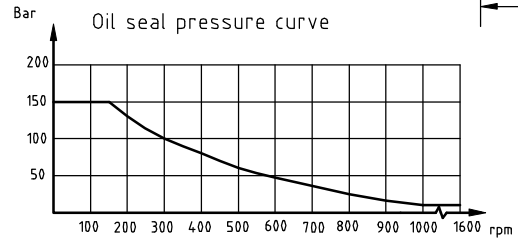
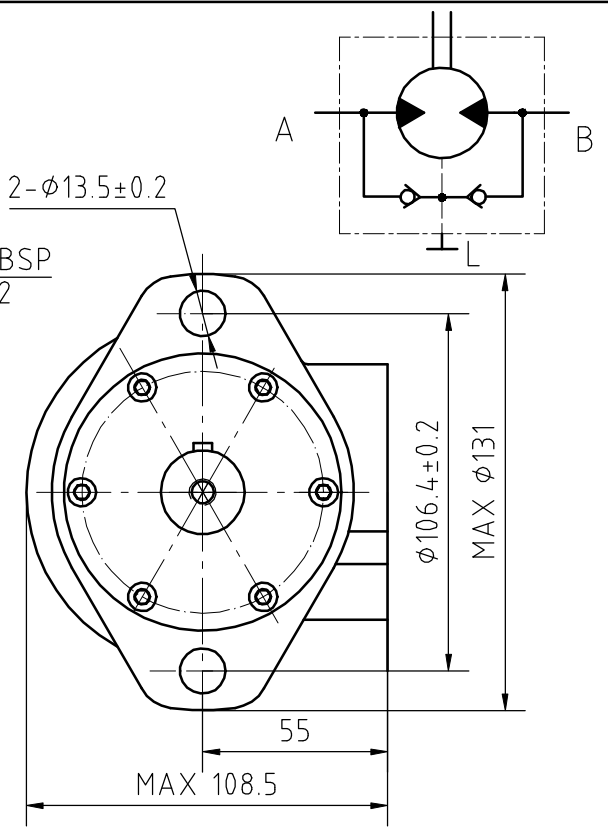
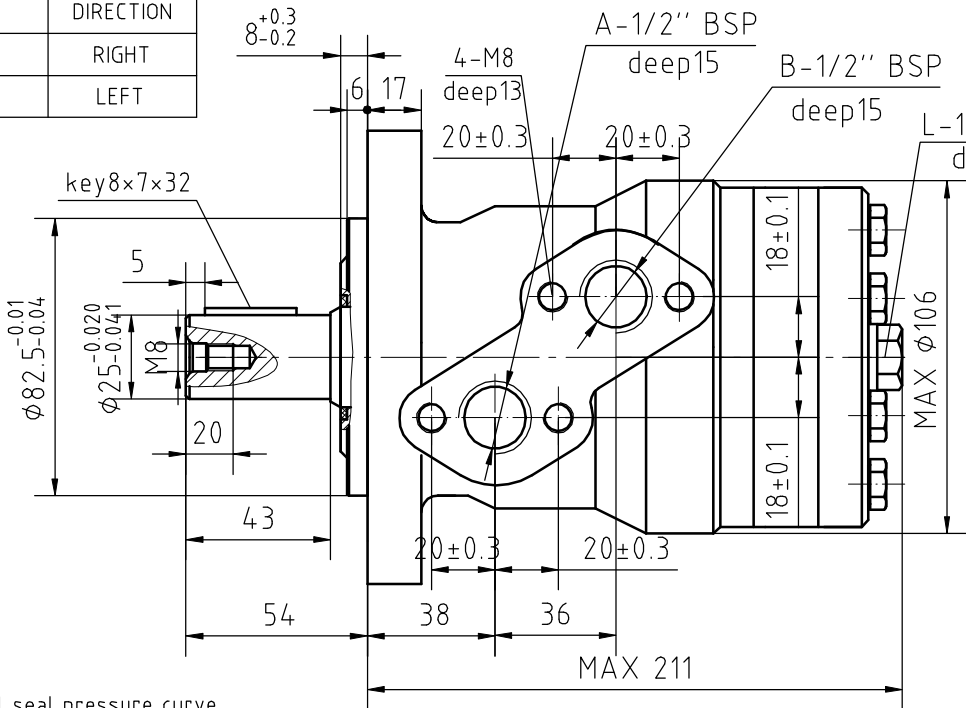

PRESSURE(bar)		
CONTINUOUS	INTERMITTENT	PEAK
100	120	140
Type:Geroller		

Max allowed back-pressure or drain pressure: 150bar  
 Max allowed torque :500Nm  
 Max speed: 150rpm  
 PAINTING COLOUR:BLACK  
 PAINTING THICKNESS RANGE: 0.04mm-0.06mm  
 SHAFT AND FRONT HOUSING: MAGNESIUM PHOSPHATED

<b>forward products</b>	Date 06.03.2019
Nom.Displacement 400cc/rmp	
FP-MR400-2H-CY25-01	